

VHR 12SCG100 (12V100Ah)

Superior Cycle Gel Battery

HRESYS SCG series is Superior Cycle VRLA Gel battery. By combining the newly developed nano gel electrolyte and high cyclic paste, SCG series delivers high cycle life, excellent high&low temperature performance, it is highly suited for renewable energy systems, outdoor telecom and other harsh environment require high cycle applications.



TECHNICAL SPECIFICATIONS

Nominal Voltage (V)	12 (6 cells per unit)
Designed Floating Life (25°C)	12 Years
Nominal Capacity (25°C)	100 Ah @ 10HR-rate (to 1.80Vpc)
Dimension (mm)	L330mm x W174mm x H220mm
Approx. Weight	28.1 kg (61.9 lbs)
Terminal Type	F-M8 or cable (torque:10~12N.m for F-M8)
Internal Resistance	Approx. 0.005 Ohm (fully charged @ 20°C)
Max. Charge Current	25A
Max. Discharge Current (5S)	800 A
Short Circuit Current	2600 A
Self Discharge	Approx. 2.5% per month @ 20°C
Ambient Temperature	Discharge: -40~60°C Charge: -20~55°C Storage: -25~45°C
Float Charge Voltage	13.5-13.62V/block @25°C (-3mV/ cell/°C)
Equalize and cycle Use Charge Voltage	14.1-14.4V/block @25°C
Container Material	ABS (UL94-V0 optional)



Complied standards

- IEC 60896-21/22
- GB/T19638
- IEC61427
- JIS C8704
- BS6290 part 4

BATTERY DIMENSIONS

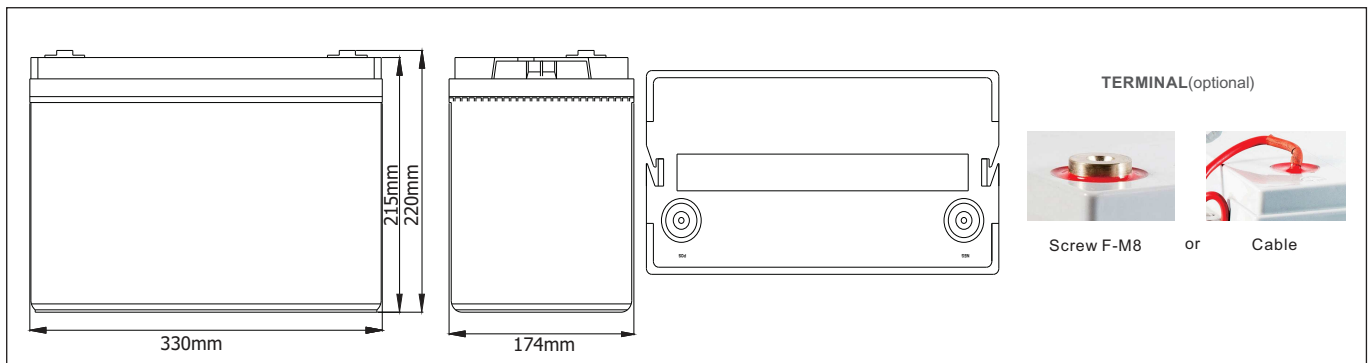

BATTERY DISCHARGE TABLE

Constant Current Discharge Characteristics: Amps (25°C)									
F.V/Time	30min	1h	2h	3h	4h	5h	8h	10h	20h
1.70V	104	64.3	38.1	27.7	22.1	18.4	12.5	10.3	5.45
1.75V	100	63.0	37.4	27.2	21.8	18.2	12.4	10.2	5.35
1.80V	95.6	60.9	36.6	26.7	21.3	17.7	12.1	10.0	5.25
1.85V	90.2	58.3	35.2	25.8	20.7	17.3	11.8	9.74	5.13

Constant Power Discharge Characteristics: W/cell (25°C)									
F.V/Time	30min	1h	2h	3h	4h	5h	8h	10h	20h
1.70V	194	121	72.5	52.9	42.4	35.5	24.4	20.2	10.7
1.75V	189	120	71.8	52.6	42.3	35.4	24.3	20.1	10.6
1.80V	182	117	70.9	52.0	41.7	34.8	23.9	19.9	10.5
1.85V	174	113	68.8	50.7	40.8	34.3	23.5	19.5	10.3

PARAMETERS FOR SOLAR & WIND APPLICATIONS

Long time discharge capacity for Solar & Wind applications

Capacity	C ₂₄ (Ah)	C ₄₈ (Ah)	C ₇₂ (Ah)	C ₁₀₀ (Ah)	C ₁₂₀ (Ah)
VHR12SCG100	107	113	116	121	125
Final Voltage	1.85V				

Solar & Wind applications parameters settings

Over voltage disconnect:	2.45±0.01V/cell @ 25°C
Regulation/equalize voltage:	2.40±0.01V/cell @ 25°C
Array reconnection voltage:	2.25±0.005V/cell @ 25°C
Float voltage setting:	2.27±0.005V/cell @ 25°C
Low voltage alarm voltage:	1.95±0.005V/cell @ 25°C
Low voltage disconnect:	1.90±0.005V/cell @ 25°C
Load reconnect voltage:	2.09±0.01V/cell @ 25°C
Temp. compensate coefficient:	-5mV/cell/°C

